

SHIPPING WEIGHT =

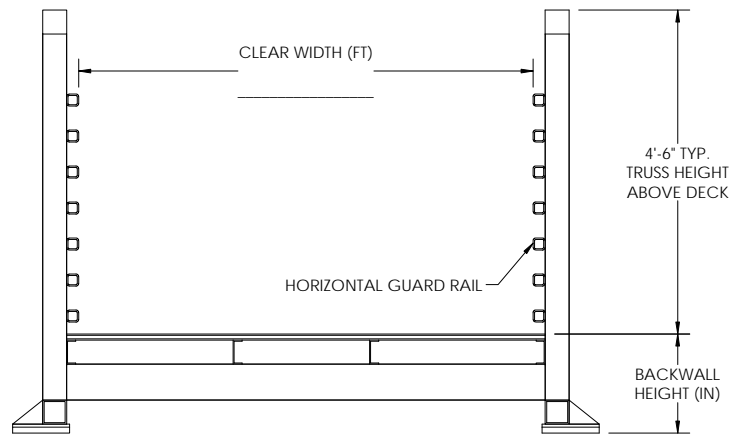

SECTION VIEW

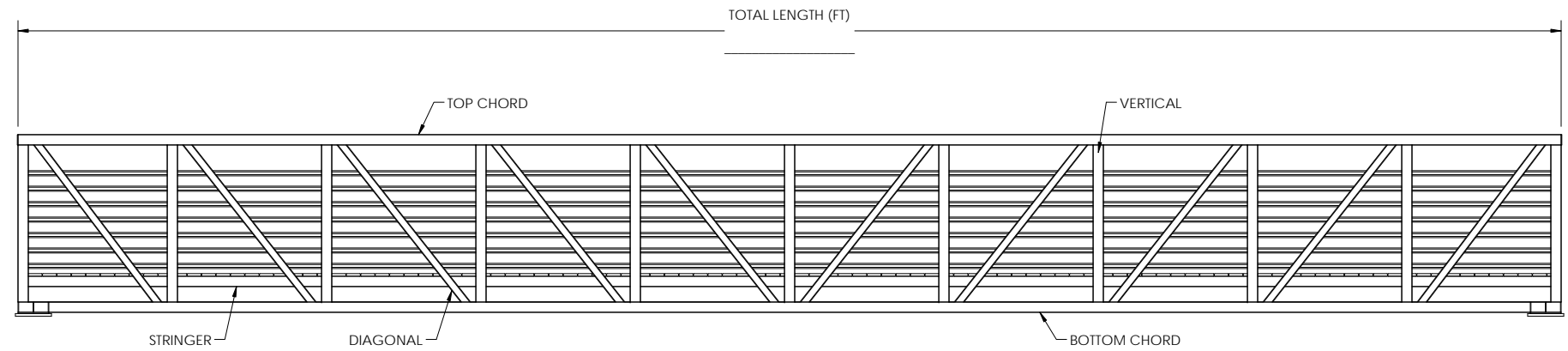

BRIDGE ELEVATION

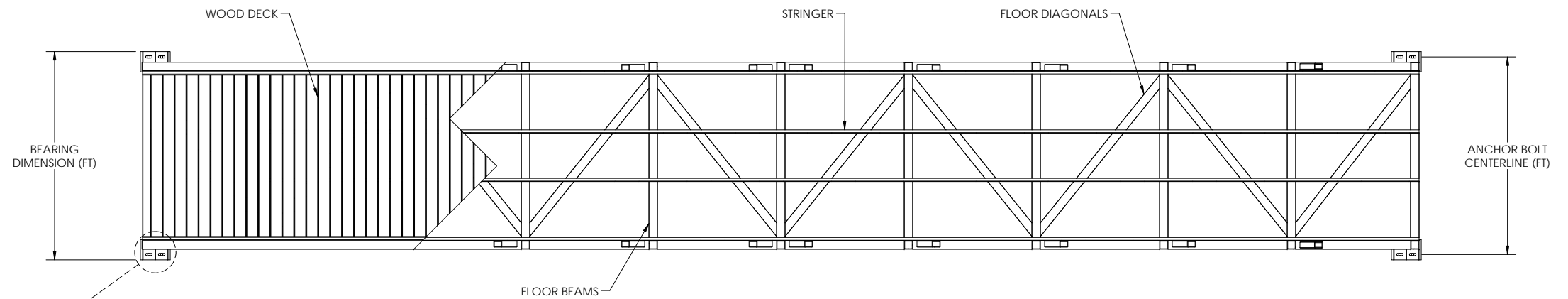

BRIDGE PLAN

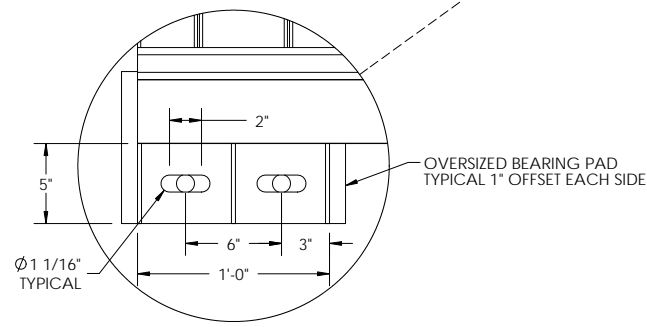

DETAIL 1

GENERAL NOTES:

1. BRIDGE BEARINGS SHALL BE CONSTRUCTED AT SAME LEVEL
2. BRIDGE SETTING PLATES SHALL BE UHMW OR TEFLON COATED STEEL AND SHALL BE SHIPPED LOOSE FROM BRIDGE
3. ANCHOR DESIGN AND INSTALLATION SHALL BE BY OTHERS - NO RESPONSIBILITY ACCEPTED FOR WORK BY OTHERS
4. BRIDGE INSTALLATION SHALL BE BY OTHERS - NO RESPONSIBILITY ACCEPTED FOR WORK BY OTHERS
5. BRIDGE MAY BE CAMBERED DURING FABRICATION TO OFFSET DEAD LOAD DISPLACEMENT
6. STEEL COMPONENTS SHALL BE WEATHERING STEEL
7. HSS SQUARE & RECTANGULAR TUBING SHALL BE ASTM A847 (YIELD 50KSI MINIMUM)
8. PLATE, ANGLE, & CHANNEL SHALL BE ASTM A588 (YIELD 50KSI MINIMUM)
9. MECHANICAL SPLICE FASTENERS SHALL BE ASTM A325
10. STEEL WELDING SHALL CONFORM TO AWS D1.1
11. DEBUR ALL EXPOSED WELDS WHICH MAY COME IN CONTACT WITH PEDESTRIANS
12. ALL EXPOSED SURFACES OF TRUSS & DECK FRAME SHALL BE BLAST CLEANED IN ACCORDANCE WITH SSPC-SP7

*THE VIEWS AND DETAILS DEPICTED ON THIS PAGE ARE TYPICAL AND DO NOT REPRESENT ANY SPECIFIC PROJECT DESIGN.



57 OLD IVY SQUARE, ATLANTA, GA 30342
(866) 258-3401, WWW.BRIDGEBROTHERSINC.COM

PRATT PEDESTRIAN BRIDGE

CUSTOMER:

PROJECT #

APPROVAL INITIALS:

TOLERANCES UNLESS SPECIFIED OTHERWISE
XXX = ±1/4"; FRACTIONS = ±1/8"; ANGULAR = ±1°

DRAWN BY:

SHEET
1 of 1

CHECKED BY:

PRELIMINARY DRAWING

SCALE: N/A

BRIDGE REACTIONS

	Z (LBS)	Y (LBS)	X (LBS)
DEAD LOAD	---	---	---
VEHICLE LOAD (10,000 LBS)	---	---	---
LIVE LOAD (@ 90PSF)	---	---	---
HORIZONTAL WIND (@ 46.2PSF) OVERTURNING WIND (@ 20PSF)			---
THERMAL (COEFF OF FRICTION 0.2)	---	---	---

BRIDGE LIFTING WEIGHT =
THERMAL EXPANSION (BASED ON A SEASONAL TEMPERATURE VARIATION OF 120°F)
Y = VERTICAL LOAD @ EACH BEARING PLATE (4 TOTAL)
Z = HORIZONTAL LOAD @ EACH FOOTING (2 PER BRIDGE, 1 @ EACH END)
X = LONGITUDINAL LOAD @ EACH FIXED BEARING PLATE (2 PER BRIDGE)

THE INFORMATION CONTAINED IN THIS DRAWING IS THE SOLE PROPERTY OF BRIDGE BROTHERS, LLC. ANY REPRODUCTION IN PART OR AS A WHOLE WITHOUT THE WRITTEN PERMISSION OF BRIDGE BROTHERS, LLC IS PROHIBITED.